

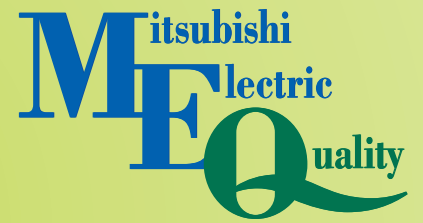

Changes for the Better

AIR TO WATER HEAT PUMP SYSTEMS



ecodan

Renewable Heating Technology

DATA BOOK

Vol.4.1

for a greener tomorrow



Model Name			PUHZ-SHW140YHA(-BS)	PUHZ-SHW230YKA2	
Power supply (phase, cycle, voltage)			3φ, 400V, 50Hz	3φ, 400V, 50Hz	
	Max. current	A	13.0	20.0	
Breaker size			16	25	
Outer casing			Galvanized plate	Galvanized plate	
External finish			Munsell 3Y 7.8/1.1	Munsell 3Y 7.8/1.1	
Refrigerant control			Linear expansion valve	Linear expansion valve	
Compressor			Hermetic scroll	Hermetic scroll	
	Model		ANB33FJQMT	ANB66FJNMT	
	Motor output	kW	2.5	4.7	
Start type			Inverter	Inverter	
Protection devices			HP switch LP switch Discharge thermo Comp. Surface thermo	HP switch LP switch Discharge thermo Comp. Surface thermo Orver current detection	
	Oil (Model)	L	1.40 (FVC68D)	1.70 (FV50S)	
Crankcase heater			W	-	
Heat exchanger		Air	Plate fin coil	Plate fin coil	
		Water	-	-	
Fan		Fan(drive) x No.	Propeller fan ×2	Propeller fan ×2	
		Fan motor output	kW	0.074 ×2	0.150 ×2
		Air flow	m ³ /min(CFM)	100 (3,530)	140 (4,940)
Defrost method			Reverse cycle	Reverse cycle	
Noise level (SPL)		Heating	dB(A)	52	59
		Cooling	dB(A)	51	58
Noise level (PWL)		Heating	dB(A)	70	75
Dimensions		Width	mm(in)	950 (37-3/8)	1050 (41-5/16)
		Depth	mm(in)	330+30 (13+1-3/16)	330+30 (13+1-3/16)
		Height	mm(in)	1350 (53-1/8)	1338 (52-11/16)
Weight			kg(lbs)	134 (296)	143(315)
Refrigerant (GWP)			R410A (1975)	R410A (1975)	
	Quantity	kg(lbs)	5.5 (12.1)	7.1 (15.7)	
Pipe size O.D.		Liquid	mm(in)	9.52 (3/8)	12.7 (1/2)
		Gas	mm(in)	15.88 (5/8)	25.4 (1)
Connection method			Flared	Flared	
Between the indoor & outdoor unit		Height difference	m	Max. 30	Max. 30
		Piping length	m	2 to 75	2 to 80
Guaranteed operating range (Outdoor)		Heating	°C	-28 (*1) to +21	-25 to +21
		DHW	°C	-28 (*1) to +35	-25 to +35
		Cooling *2	°C	-15 to +46	-15 to +46
Outlet water temp. (Max in heating, Min in cooling)		Heating	°C	+60	+60
		Cooling	°C	+5	+5
Nominal return water temperature range		Heating	°C	+10 to +59	+10 to +59
		Cooling	°C	+8 to +28	+8 to +28
Water flow rate range			L/min	17.9 to 40.1	28.7 to 65.9

*1 Service reference number from "R2" (before "R2" : -25°C)

*2 Optional air protection guide is required where ambient temperature is lower than -5°C.
The temperature is 10°C when the unit is connected with Cylinder unit or Hydrobox.
For more details, refer to "Cylinder unit / Hydrobox".

■ Zubadan

Model name			PUHZ-SHW80VHA(-BS)	PUHZ-SHW112VHA(-BS)
Nominal water flow rate (Heating mode)		L/min	22.9	32.1
Heating (A7/W35)	Capacity	kW	8.00	11.20
	COP		4.65	4.46
	Power input	kW	1.72	2.51
Heating (A2/W35)	Capacity	kW	8.00	11.20
	COP		3.55	3.34
	Power input	kW	2.25	3.35
Pressure difference (water circuit)		kPa	-	-
Heating pump input (based on EN14511)		kW	-	-
Nominal water flow rate (Cooling mode)		L/min	20.4	28.7
Cooling (A35/W7)	Capacity	kW	7.10	10.00
	EER (COP)		3.31	2.83
	Power input	kW	2.15	3.53
Cooling (A35/W18)	Capacity	kW	7.10	10.00
	EER (COP)		4.52	4.74
	Power input	kW	1.57	2.11
Pressure difference (water circuit)		kPa	-	-
Cooling pump input (based on EN14511)		kW	-	-
Recommended plate heat exchanger			ACH70-40	ACH70-40

The table shows performance data obtained when a plate heat exchanger is connected.

Model name			PUHZ-SHW112YHA(-BS)	PUHZ-SHW140YHA(-BS)
Nominal water flow rate (Heating mode)		L/min	32.1	40.1
Heating (A7/W35)	Capacity	kW	11.20	14.00
	COP		4.46	4.22
	Power input	kW	2.51	3.32
Heating (A2/W35)	Capacity	kW	11.20	14.00
	COP		3.34	2.96
	Power input	kW	3.35	4.73
Pressure difference (water circuit)		kPa	-	-
Heating pump input (based on EN14511)		kW	-	-
Nominal water flow rate (Cooling mode)		L/min	28.7	35.8
Cooling (A35/W7)	Capacity	kW	10.00	12.50
	EER (COP)		2.83	2.17
	Power input	kW	3.53	5.76
Cooling (A35/W18)	Capacity	kW	10.00	12.50
	EER (COP)		4.74	4.26
	Power input	kW	2.11	2.93
Pressure difference (water circuit)		kPa	-	-
Cooling pump input (based on EN14511)		kW	-	-
Recommended plate heat exchanger			ACH70-40	ACH70-40

The table shows performance data obtained when a plate heat exchanger is connected.

■Zubadan

- PUHZ-SHW80/112VHA(-BS)**
- PUHZ-SHW112/140YHA(-BS)**
- PUHZ-SHW230YKA2**

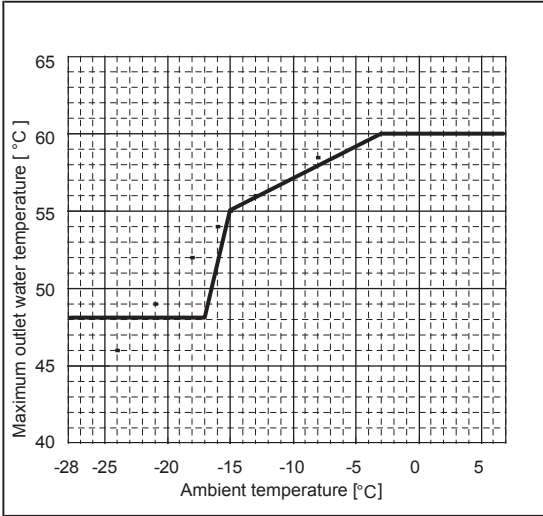

*PUHZ-SHW80/112/140 Service reference number from "R2": down to -28°C
Before "R2" and PUHZ-SHW230 : down to -25°C

- PUHZ-SHW80/112VAA(-BS)**
- PUHZ-SHW80/112YAA(-BS)**

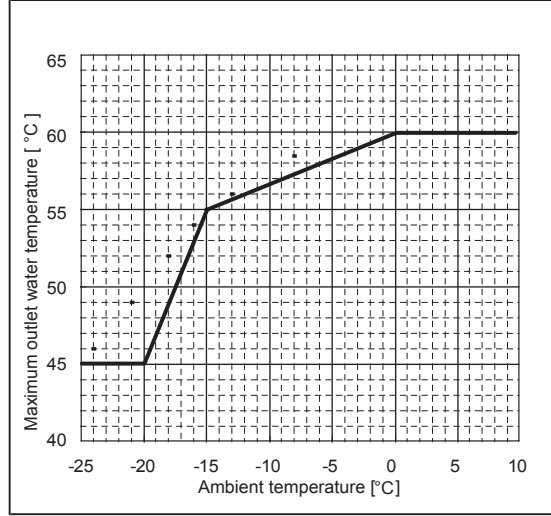

■Inverter multi

- PUMY-P112/125/140VKM4(-BS)**
- PUMY-P112/125/140YKM4(-BS)**
- PUMY-P112/125/140YKME4(-BS)**

Maximum outlet water temperature curve at single operation of ATW Heating

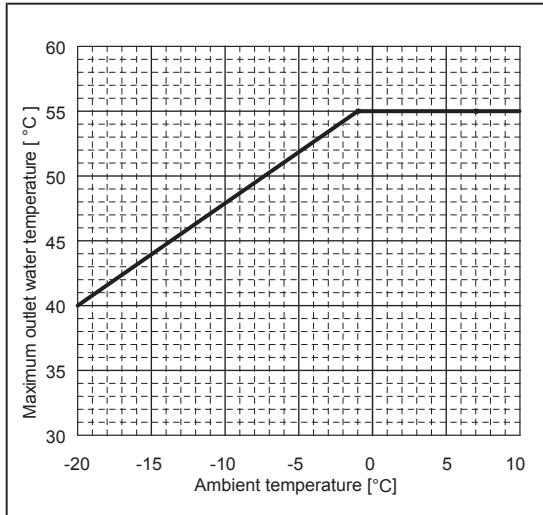

Maximum outlet water temperature curve at simultaneous operation of ATA Heating and ATW heating

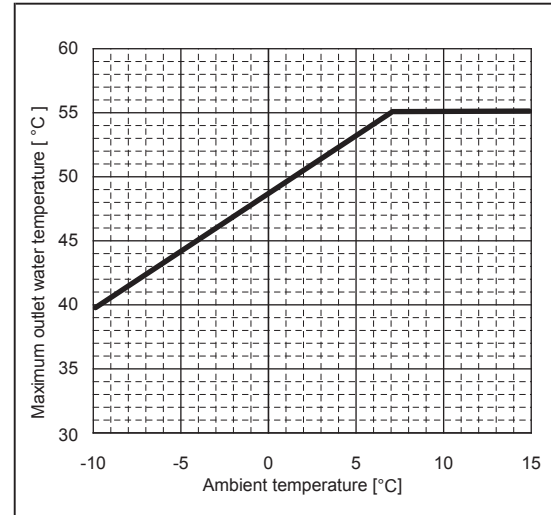

(2) Split-type units*

* When a recommended plate heat exchanger is installed.

■ Heating

SUHZ-SW45VA(H)
PUHZ-SW50VKA(-BS)

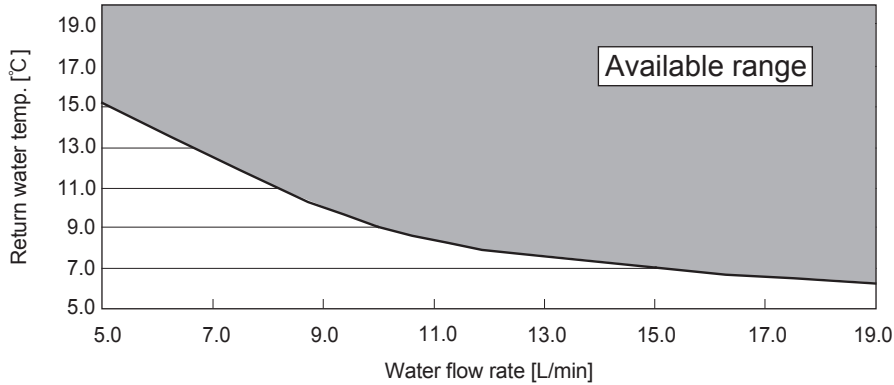

PUHZ-SW75VHA(-BS) PUHZ-SW75VAA(-BS)
PUHZ-SHW80VHA(-BS) PUHZ-SW75YAA(-BS)

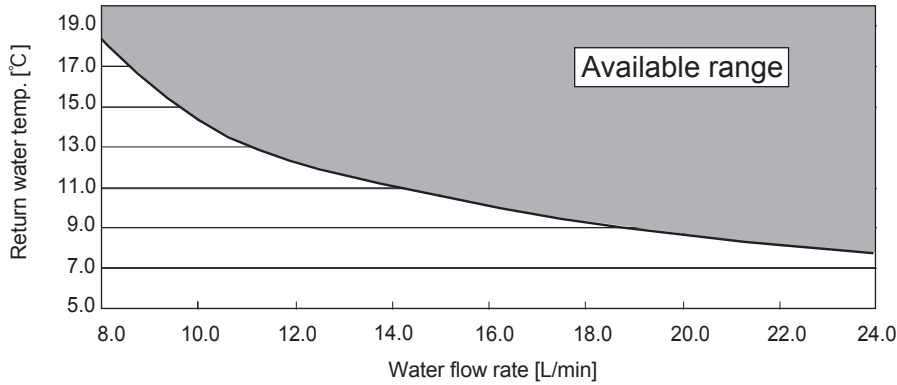

PUHZ-SW100/120VHA(-BS) PUHZ-SHW112VHA(-BS)
PUHZ-SW100/120YHA(-BS) PUHZ-SHW112/140YHA(-BS)
PUHZ-SW100VAA(-BS) PUHZ-SHW80/112VAA(-BS)
PUHZ-SW100YAA(-BS) PUHZ-SHW80/112YAA(-BS)

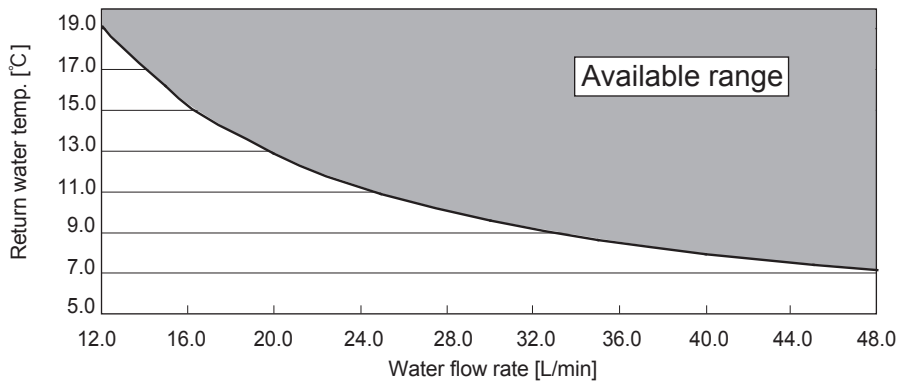

PUHZ-SW160YKA(-BS) PUHZ-SW200YKA(-BS)

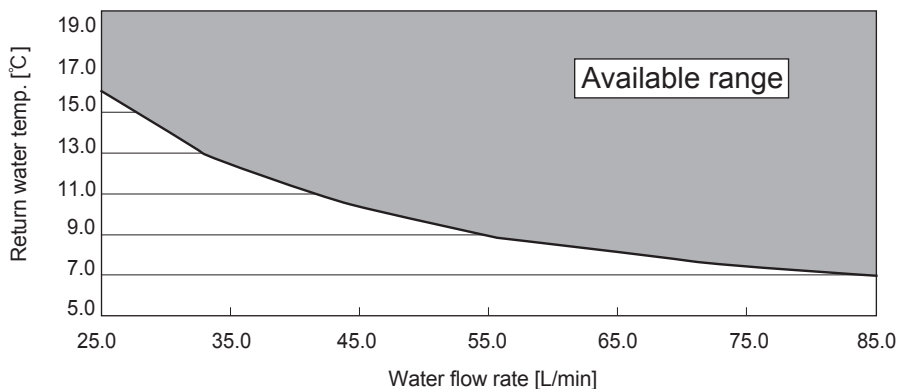

2 Outlines and dimensions

Outdoor unit

- PUAZ-SW100/120VHA(-BS)
- PUAZ-SW100/120YHA(-BS)
- PUAZ-SHW80/112VHA(-BS)
- PUAZ-SHW112YHA(-BS)

Unit : mm

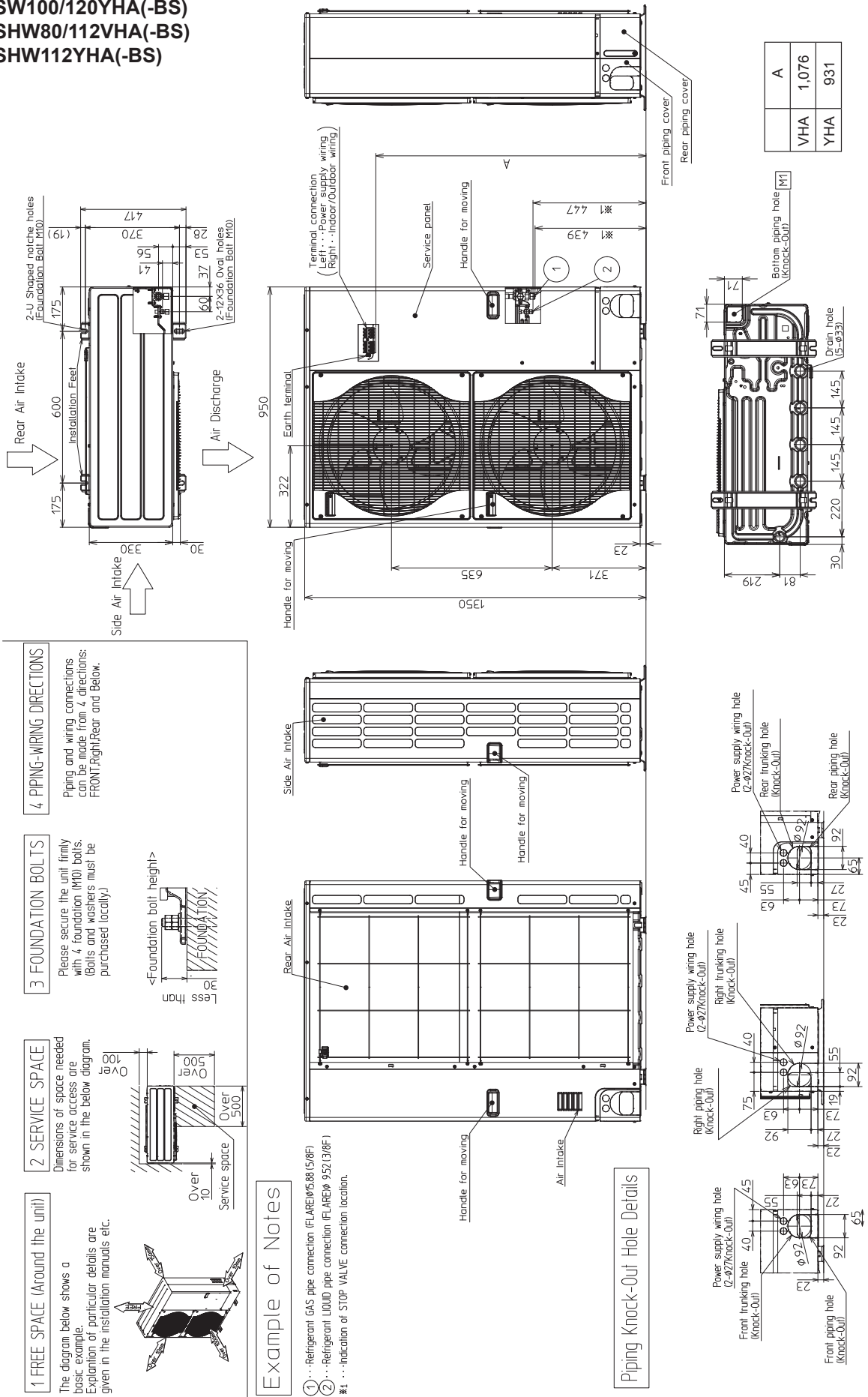

PUHZ-SHW112/140YHA(-BS)

Outdoor unit

SYMBOL	NAME	SYMBOL	NAME	SYMBOL	NAME
TB1	Terminal Block <Power Supply>	TH33	Thermistor <Ref. check>	SW5	Switch <Function Switch, Model Select>
TB2	Terminal Block <Indoor/Outdoor>	TH34	Thermistor <Comp. Surface>	SW6	Switch <Model Select>
MC	Motor for Compressor	LEV-A, LEV-B, LEV-C	Linear Expansion Valve	SW7	Switch <Function Switch>
MF1, MF2	Fan Motor	ACL1, ACL2, ACL3, ACL4	Reactor	SW8	Switch <Function Switch>
21S4	Solenoid Valve (4-Way Valve)	CY1, CY2	Capacitor	SW9	Switch <Function Switch>
63H	High Pressure Switch	CK	Capacitor	SWP	Switch <Pump Down>
63L	Low Pressure Switch	RS	Rush Current Protect Resistor	CN31	Connector <Emergency Operation>
63HS	High Pressure Sensor	P. B.	Power Circuit Board	CNDM	Connector <Connector for Option>
TH3	Thermistor <Liquid>	N. F.	Noise Filter Circuit Board	SV1/CH	Connector <Connection for Option>
TH4	Thermistor <Discharge>	CONV. B.	Converter Circuit Board	SV3/SS	Connector <Connection for Option>
TH6	Thermistor <2-Phase Pipe>	C. B.	Controller Circuit Board	CNM	Connector <Connection for Option>
TH7	Thermistor <Ambient>	SW1	Switch <Manual Defrost, Defect History Record Reset, Refrigerant Address>	F1, F2, F3, F4	Fuse <T6.3AL250V>
TH8	Thermistor <Heat Sink>	SW4	Switch <Test Operation>		
TH32	Thermistor <Suction>				

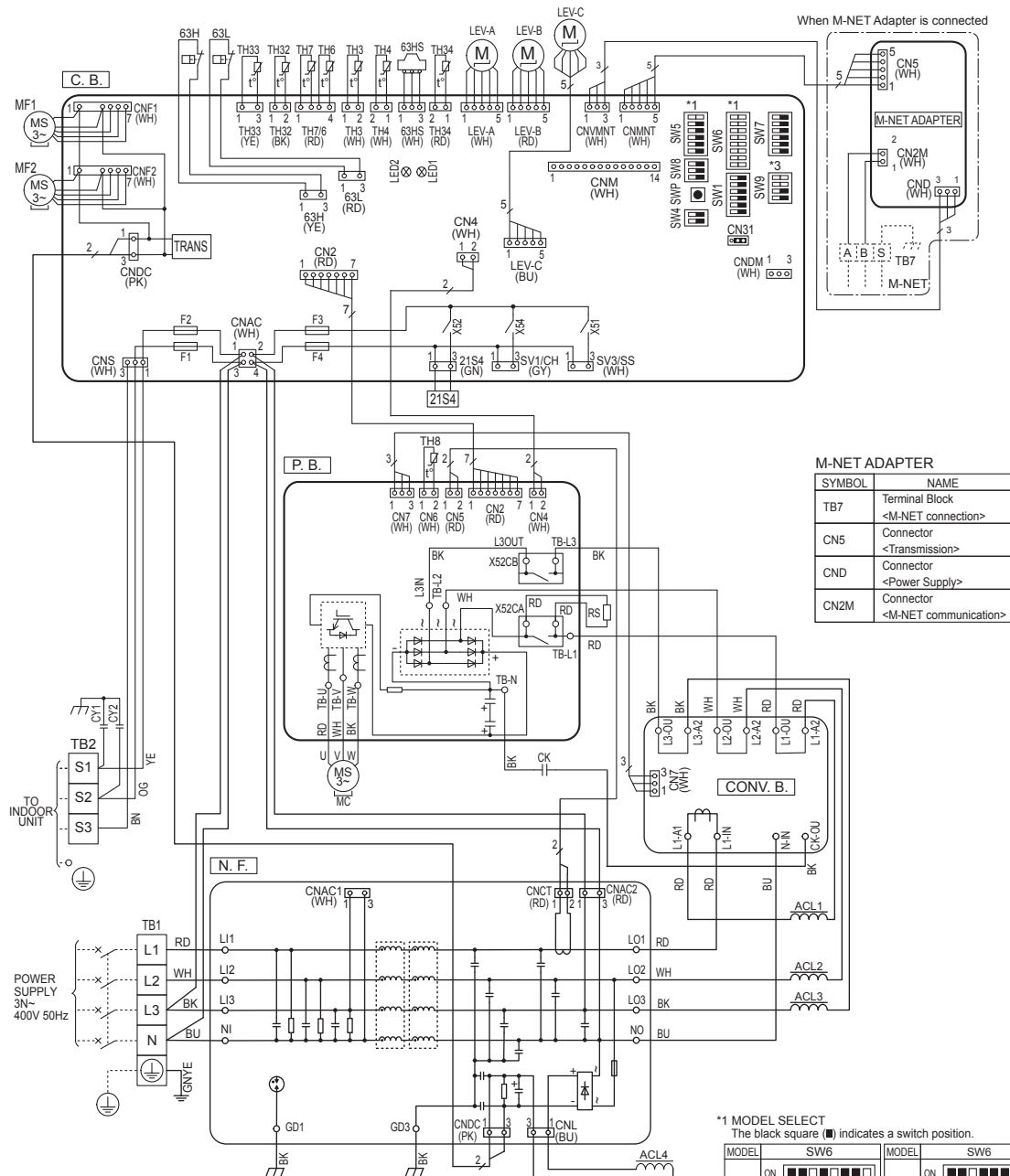

*3 Ambient temp. of ZUBADAN Flash Injection becomes effective.
The black square (■) indicates a switch position.

Ambient temp. SW9-3, 9-4 *4	Ambient temp. SW9-3, 9-4 *4	Ambient temp. SW9-3, 9-4 *4	Ambient temp. SW9-3, 9-4 *4
3°C or less (Default setting)	0°C or less	-3°C or less	-6°C or less

*4 SW9-1 to 2 : Function Switch

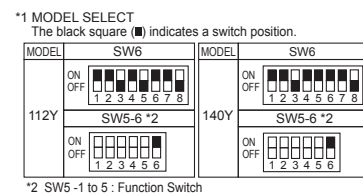

■ PUAZ-SHW80VHA(-BS)
PUAZ-SHW112YHA(-BS)

PUAZ-SHW112VHA(-BS)
PUAZ-SHW140YHA(-BS)

Unit : mm (inch)

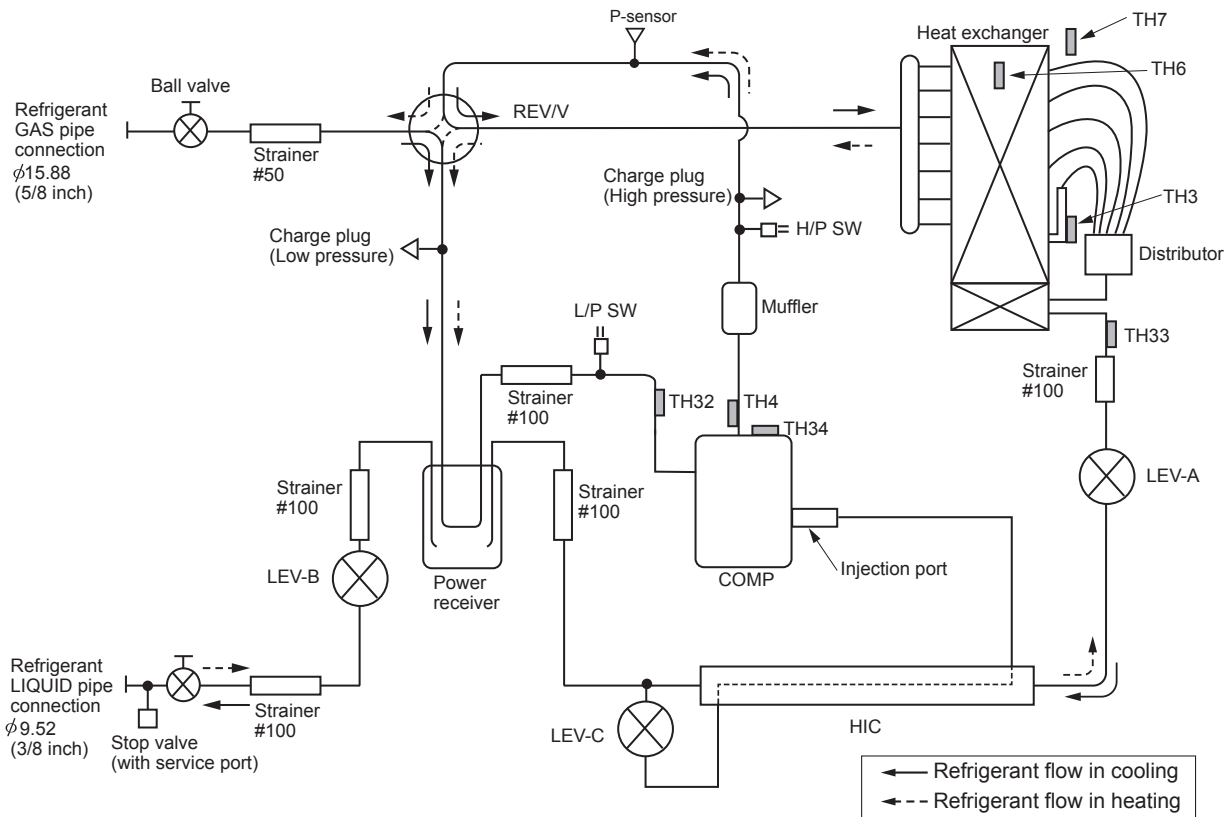

■ PUAZ-SHW230YKA2

Unit : mm (inch)

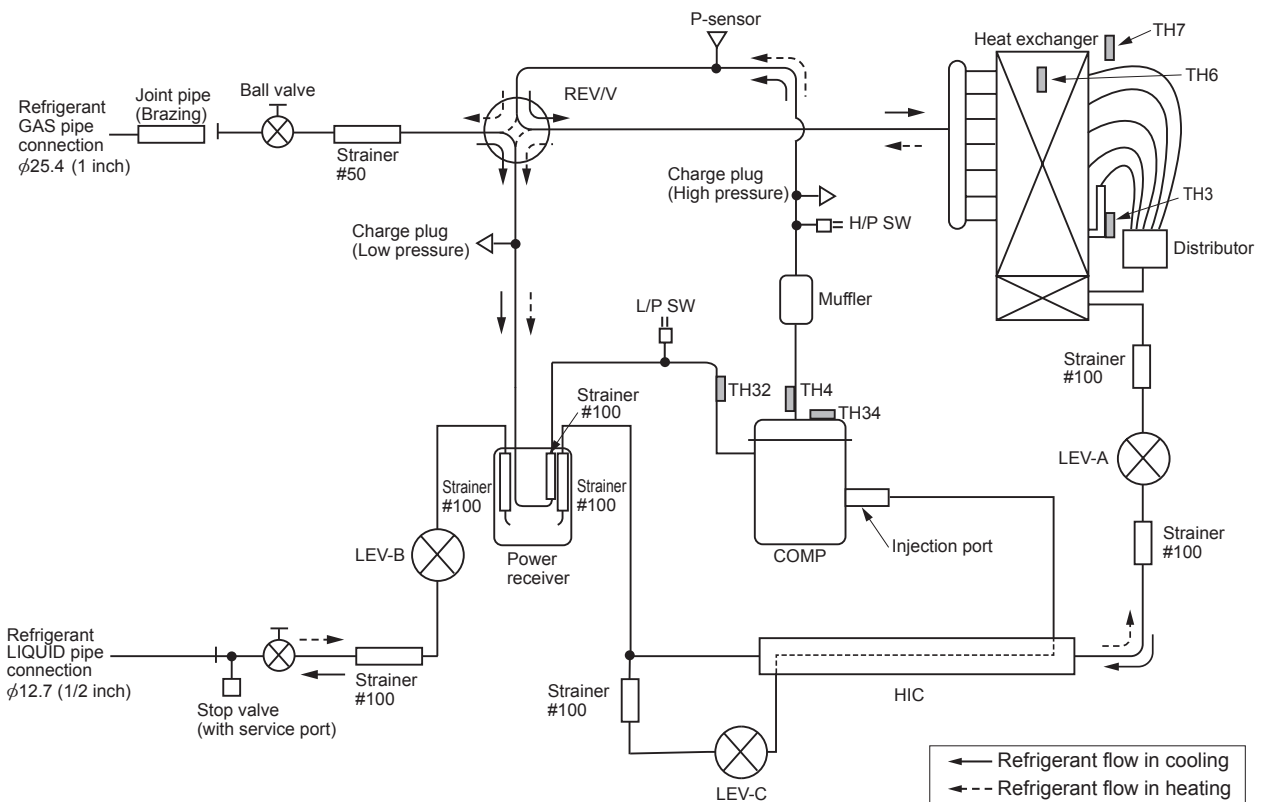

5 Performance data

Outdoor unit

Outdoor unit

■ PUHZ-SHW140YHA(-BS)

Water outlet temperature[°C]		25		35		40		45		50		55		60	
Ambient temperature[°C]		Capacity	COP	Capacity	COP	Capacity	COP	Capacity	COP	Capacity	COP	Capacity	COP	Capacity	COP
Max	(INJ) -28	-	-	9.0	1.85	9.0	1.68	9.0	1.50	-	-	-	-	-	-
	(INJ) -25	-	-	10.1	1.93	10.1	1.76	10.1	1.57	-	-	-	-	-	-
	(INJ) -20	-	-	11.8	2.08	11.8	1.89	11.8	1.69	-	-	-	-	-	-
	(INJ) -15	-	-	14.0	2.15	14.0	1.95	14.0	1.75	13.3	1.57	13.0	1.37	-	-
	(INJ) -10	15.2	2.64	15.0	2.33	15.0	2.11	14.9	1.89	14.6	1.71	14.3	1.51	-	-
	(INJ) -7	15.9	2.76	15.7	2.44	15.5	2.21	15.4	1.98	15.3	1.80	15.1	1.60	-	-
	(INJ) 2	16.8	3.02	15.8	2.71	15.3	2.43	14.8	2.16	14.6	1.95	14.4	1.72	13.8	1.47
	7	17.3	4.33	16.4	3.79	16.0	3.39	15.6	2.98	15.2	2.73	14.8	2.45	14.4	2.22
	12	20.0	4.78	19.0	4.23	18.2	3.75	17.5	3.27	17.1	3.00	16.6	2.70	16.3	2.48
	15	21.5	5.05	20.6	4.52	19.6	3.98	18.6	3.43	18.2	3.20	17.7	2.94	17.8	2.64
20	22.6	5.21	21.6	4.69	21.1	4.20	20.6	3.72	20.1	3.42	19.6	3.09	19.5	2.81	
Nominal	(INJ) -28	-	-	9.0	1.85	9.0	1.68	9.0	1.50	-	-	-	-	-	-
	(INJ) -25	-	-	10.1	1.93	10.1	1.76	10.1	1.57	-	-	-	-	-	-
	(INJ) -20	-	-	11.8	2.08	11.8	1.89	11.8	1.69	-	-	-	-	-	-
	(INJ) -15	-	-	14.0	2.15	14.0	1.95	14.0	1.75	13.3	1.57	13.0	1.37	-	-
	(INJ) -10	14.0	2.77	14.0	2.42	14.0	2.17	14.0	1.92	14.0	1.73	14.0	1.53	-	-
	(INJ) -7	14.0	2.98	14.0	2.58	14.0	2.30	14.0	2.02	14.0	1.84	14.0	1.64	-	-
	(INJ) 2	14.0	3.34	14.0	2.96	14.0	2.70	14.0	2.44	14.0	2.17	14.0	1.89	13.8	1.47
	7	14.0	4.75	14.0	4.22	14.0	3.75	14.0	3.28	14.0	2.91	14.0	2.49	14.0	2.23
	12	16.2	5.21	16.2	4.60	16.2	4.08	16.2	3.55	16.2	3.18	16.2	2.77	16.2	2.50
	15	17.6	5.52	17.6	4.86	17.6	4.29	17.6	3.73	17.6	3.36	17.6	2.96	17.6	2.66
20	19.0	5.81	19.0	5.10	19.0	4.50	19.0	3.90	19.0	3.54	19.0	3.14	19.0	2.84	
Mid	(INJ) -28	-	-	7.2	1.94	7.2	1.74	7.2	1.55	-	-	-	-	-	-
	(INJ) -25	-	-	8.0	2.02	8.0	1.82	8.0	1.62	-	-	-	-	-	-
	(INJ) -20	-	-	9.4	2.16	9.4	1.94	9.4	1.73	-	-	-	-	-	-
	(INJ) -15	-	-	11.2	2.31	11.2	2.06	11.2	1.80	10.6	1.59	10.4	1.38	-	-
	(INJ) -10	11.2	3.12	11.2	2.65	11.2	2.33	11.2	2.01	11.2	1.80	11.2	1.55	-	-
	(INJ) -7	11.2	3.38	11.2	2.85	11.2	2.50	11.2	2.14	11.2	1.91	11.2	1.66	-	-
	(INJ) 2	11.2	3.90	11.2	3.34	11.2	3.02	11.2	2.70	11.2	2.38	11.2	2.03	11.1	1.65
	7	11.2	4.98	11.2	4.45	11.2	3.94	11.2	3.44	11.2	3.06	11.2	2.64	11.2	2.34
	12	12.9	5.57	12.9	4.98	12.9	4.40	12.9	3.82	12.9	3.42	12.9	2.99	12.9	2.64
	15	14.1	5.93	14.1	5.33	14.1	4.70	14.1	4.07	14.1	3.66	14.1	3.22	14.1	2.85
20	15.2	6.47	15.2	5.67	15.2	4.99	15.2	4.31	15.2	3.90	15.2	3.44	15.2	3.04	
Min	-28	-	-	7.2	1.94	7.2	1.74	7.2	1.55	-	-	-	-	-	-
	-25	-	-	8.0	2.02	8.0	1.82	8.0	1.62	-	-	-	-	-	-
	-20	-	-	9.4	2.16	9.4	1.94	9.4	1.73	-	-	-	-	-	-
	-15	-	-	11.2	2.31	11.2	2.06	11.2	1.80	10.6	1.59	10.4	1.38	-	-
	-10	11.2	3.12	11.2	2.65	11.2	2.33	11.2	2.01	11.2	1.80	11.2	1.55	-	-
	-7	6.0	3.57	4.9	2.82	4.7	2.46	4.5	2.10	4.3	1.90	4.1	1.67	-	-
	2	8.0	4.35	5.7	3.67	5.5	3.19	5.2	2.72	5.0	2.43	4.7	2.11	-	-
	7	9.0	5.15	5.5	4.38	5.3	3.81	5.0	3.23	4.8	2.89	4.5	2.52	-	-
	12	10.5	5.69	4.4	4.88	4.2	4.23	4.0	3.58	3.8	3.20	3.6	2.78	-	-
	15	11.3	6.13	4.8	5.30	4.6	4.61	4.4	3.93	4.2	3.51	4.0	3.05	-	-
20	12.3	6.66	10.0	5.90	9.7	5.19	9.4	4.49	9.1	4.01	8.7	3.50	-	-	

PUHZ-SHW140YHA(-BS)

Water outlet temperature 35 [°C]

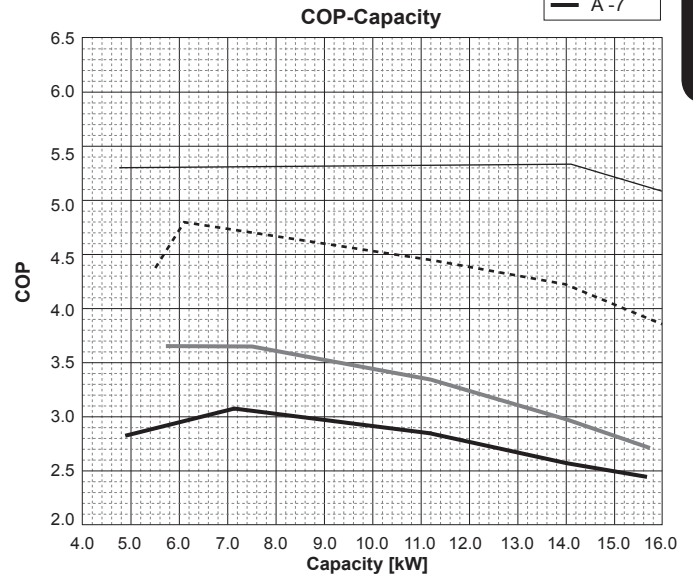
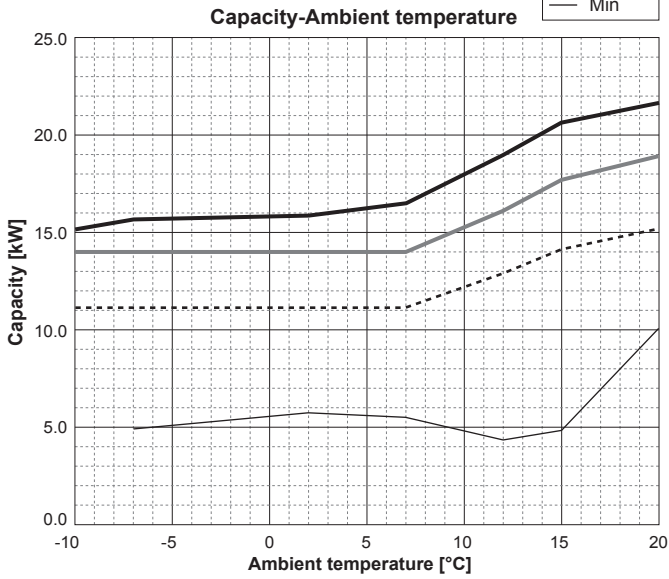

Water outlet temperature 45 [°C]

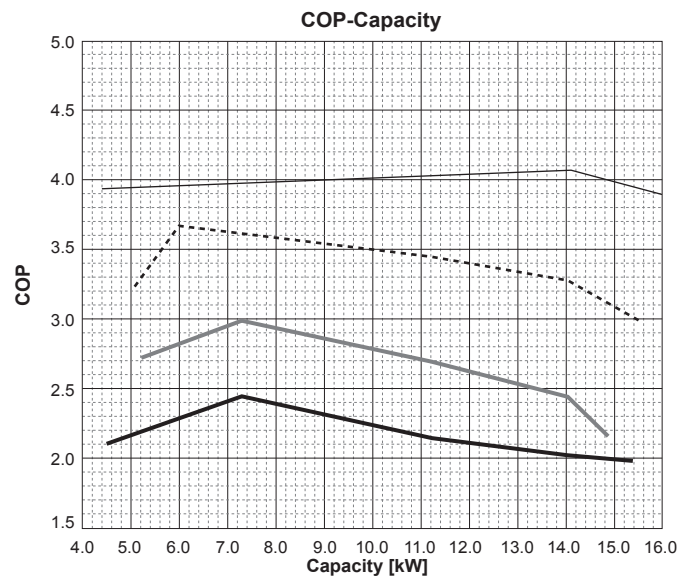
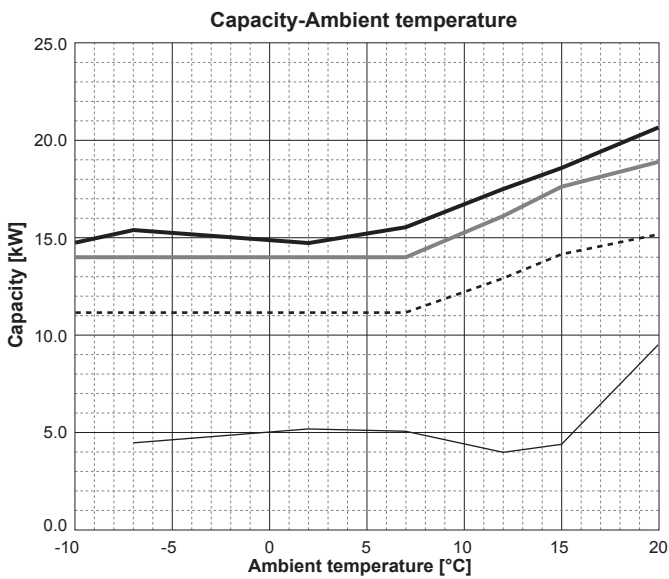

Water outlet temperature 55 [°C]

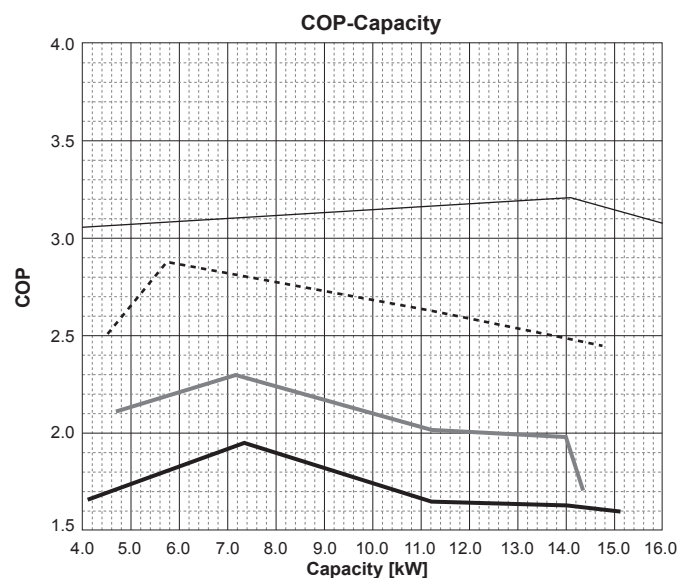
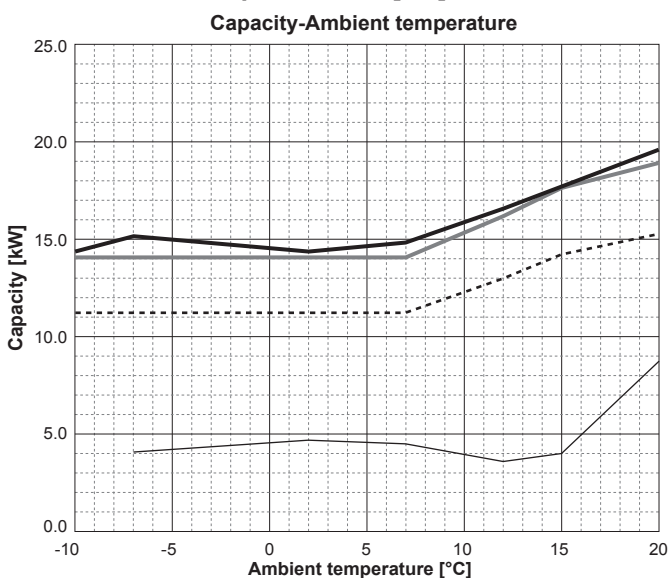

Outdoor unit

■ PUAZ-SW75VAA(-BS)
PUAZ-SW75YAA(-BS)

MODE	SPL(dB)	LINE
COOLING	45	○—○
HEATING	43	●—●

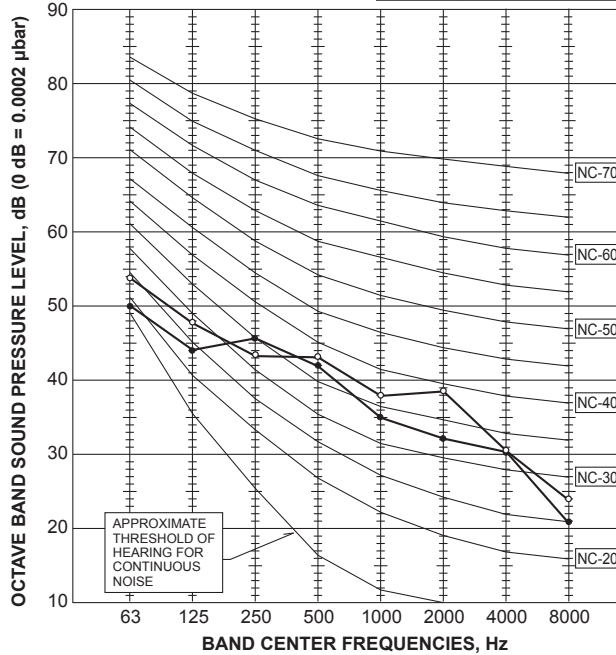

■ PUAZ-SW100VAA(-BS)
PUAZ-SW100YAA(-BS)

MODE	SPL(dB)	LINE
COOLING	49	○—○
HEATING	47	●—●

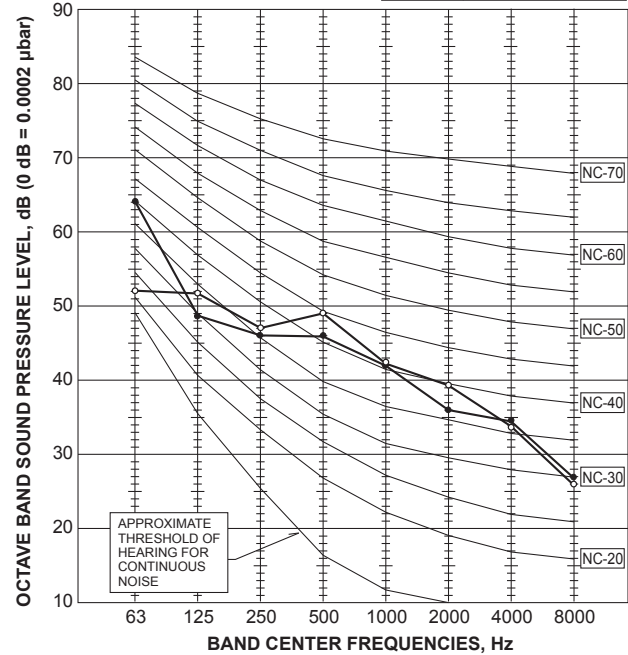

■ PUAZ-FRP71VHA2

MODE	SPL(dB)	LINE
ATA Cooling, HR Cooling	47	○—○
ATA Heating, ATW Heating	49	●—●

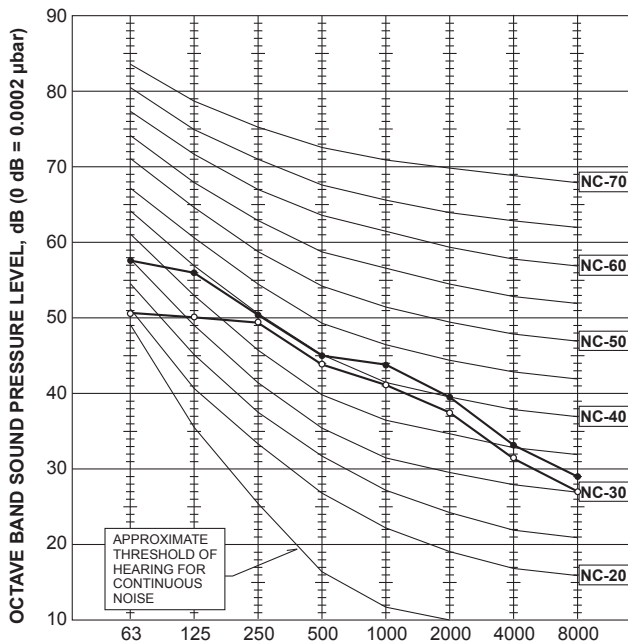

■ PUAZ-SHW80VHA(-BS)
PUAZ-SHW112VHA(-BS)
PUAZ-SHW112/140YHA(-BS)

MODE	SPL(dB)	LINE
COOLING	51	○—○
HEATING	52	●—●

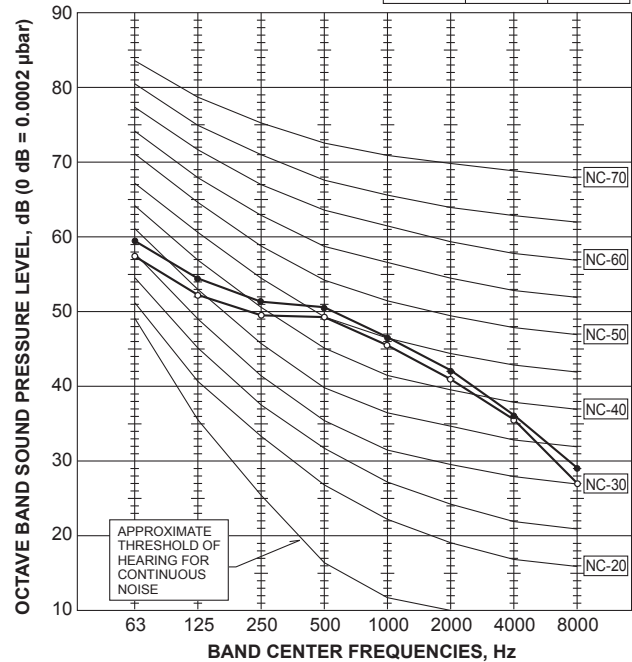

<Notes>

- 1) Sound data is taken when the system is running stably.
- 2) Relatively large noise could be heard transiently in the case 4-way valve, or LEV operates.

1.Type:

2.Model name:

3.Specification

- | | |
|---|--|
| (1) Unit mass | W= <input type="text" value="134"/> kg |
| (2) Anchor bolt | |
| 1.The total number of bolts | N= <input type="text" value="4"/> |
| 2.The size and shape | "=M <input type="text" value="10"/> type |
| 3.The axis section area per one bolt | A= <input type="text" value="78"/> mm ² = <input type="text" value="78"/> × 10 ⁻⁶ m ² |
| 4.The total number of bolts in one side which be pulled stronger when the unit inverted | Nt= <input type="text" value="2"/> |
| (3) The height between the installing surface and the center of gravity of the unit | Hg= <input type="text" value="578"/> mm= <input type="text" value="0.578"/> m |
| (4) The bolt-span from the examination angle | L= <input type="text" value="370"/> mm= <input type="text" value="0.370"/> m |
| (5) The distance between the center of bolt and the center of gravity of the unit | Lg= <input type="text" value="180"/> mm(Lg ≤ L/2)= <input type="text" value="0.180"/> m |

4.The examination calculation (by rounding off to the first decimal place of each item)

- | | |
|--|--|
| (1) The horizontal seismic coefficient for designing | Kh= <input type="text" value="1.0"/> |
| (2) The vertical seismic coefficient for designing | Kv=Kh/2= <input type="text" value="0.5"/> |
| (3) The horizontal earthquake forces for designing | Fh=Kh·W·9.8= <input type="text" value="1313.2"/> N |
| (4) The vertical earthquake forces for designing | Fv=Kv·W·9.8= <input type="text" value="656.6"/> N |
| (5) The withdrawal strength of the anchor bolt | $R_b = \frac{F_h \cdot H_g - (W \cdot 9.8 - F_v) \cdot L_g}{L \cdot N_t}$ = <input type="text" value="866.0"/> N |
| (6) The shear forces of the anchor bolt | Q=Fh/N= <input type="text" value="328.3"/> N |
| (7) The stress arising to the anchor bolt | |
| 1.The tensile stress | $\sigma = R_b/A =$ <input type="text" value="11.1"/> MPa < ft=176.4MPa |
| 2.The shearing stress | $\tau = Q/A =$ <input type="text" value="4.2"/> MPa < fs=132.3MPa |
| 3.The stress when affected by both the shearing and the tensile at the same time | $f_{ts} = 1.4\tau + 1.6\sigma =$ <input type="text" value="240.2"/> MPa |
| | $\sigma =$ <input type="text" value="11.1"/> MPa < $f_{ts} =$ <input type="text" value="240.2"/> MPa |

(8) The construction way of the anchor bolt

- | | |
|---|--|
| 1.The construction way of the anchor bolt | = <input type="text" value="Boxed J type anchor"/> |
| 2.The thickness of the concrete | = <input type="text" value="120"/> mm= <input type="text" value="0.120"/> m |
| 3.The length of buried part of bolt | = <input type="text" value="70"/> mm= <input type="text" value="0.070"/> m |
| 4.The permissible withdrawal weight | Ta= <input type="text" value="3136"/> N > Rb= <input type="text" value="866"/> N |

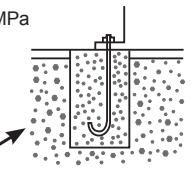

Since the results from the examination above, the anchor bolt has enough strength.

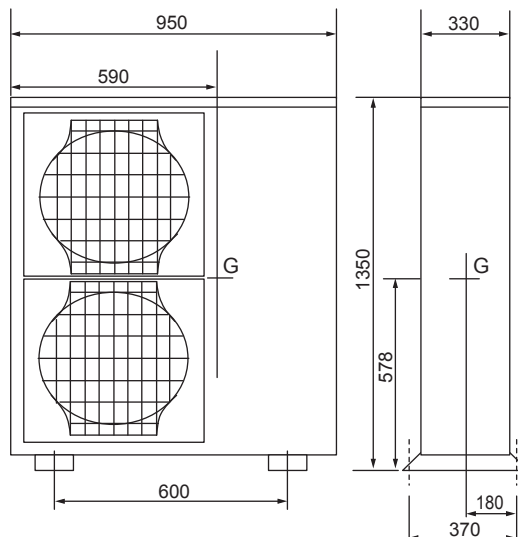

10.4 Split-type units (ZUBADAN)

PUHZ-SHW80VHA(-BS), PUHZ-SHW112VHA(-BS),
PUHZ-SHW112YHA(-BS), PUHZ-SHW140YHA(-BS),
PUHZ-SHW230YKA2

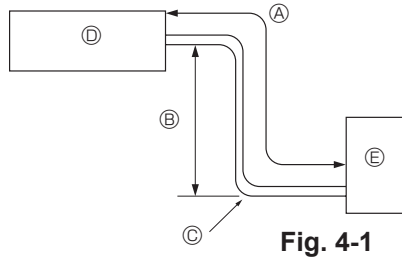
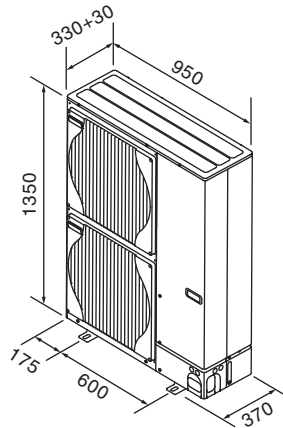

Fig. 4-1

SHW80,112,140



SHW230

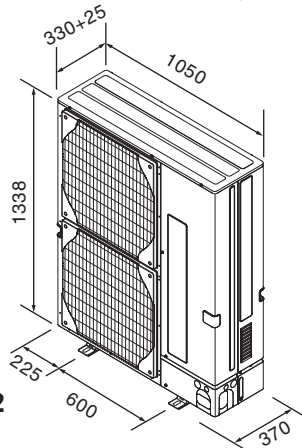

Fig. 4-2

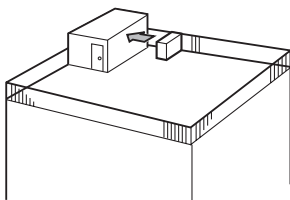

Fig. 4-3

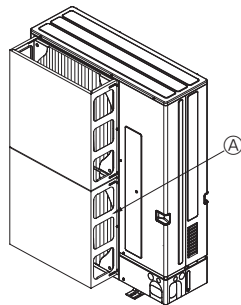

Fig. 4-4

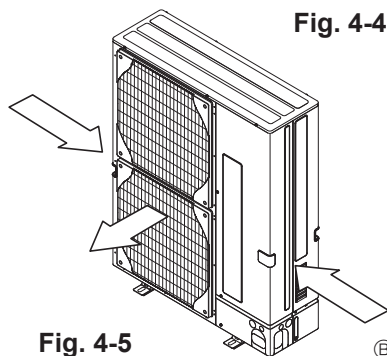

Fig. 4-5

Refrigerant pipe (Fig. 4-1)

Check that the difference between the heights of the indoor and outdoor units, the length of refrigerant pipe, and the number of bends in the pipe are within the limits shown below.

Models	Ⓐ Pipe length (one way)	Ⓑ Height difference	Ⓒ Number of bends (one way)
SHW80,112,140	2 m - 75 m	Max. 30 m	Max. 15
SHW230	2 m - 80 m	Max. 30 m	Max. 15

- Height difference limitations are binding regardless of which unit, indoor or outdoor, is positioned higher.
- ⓐIndoor unit ⓑOutdoor unit

Choosing the outdoor unit installation location

- Avoid locations exposed to direct sunlight or other sources of heat.
- Select a location from which noise emitted by the unit will not inconvenience neighbors.
- Select a location permitting easy wiring and pipe access to the power source and indoor unit.
- Avoid locations where combustible gases may leak, be produced, flow, or accumulate.
- Note that water may drain from the unit during operation.
- Select a level location that can bear the weight and vibration of the unit.
- Avoid locations where the unit can be covered by snow. In areas where heavy snow fall is anticipated, special precautions such as raising the installation location or installing a hood on the air intake must be taken to prevent the snow from blocking the air intake or blowing directly against it. This can reduce the airflow and a malfunction may result.
- Avoid locations exposed to oil, steam, or sulfuric gas.
- Use the transportation handles of the outdoor unit to transport the unit. If the unit is carried from the bottom, hands or fingers may be pinched.

Outline dimensions (Outdoor unit) (Fig. 4-2)

Ventilation and service space

(1) Windy location installation

When installing the outdoor unit on a rooftop or other location unprotected from the wind, situate the air outlet of the unit so that it is not directly exposed to strong winds. Strong wind entering the air outlet may impede the normal airflow and a malfunction may result.

The following shows three examples of precautions against strong winds.

- ① Face the air outlet towards the nearest available wall about 50 cm away from the wall. (Fig. 4-3)
- ② Install an optional air guide if the unit is installed in a location where strong winds from a typhoon, etc. may directly enter the air outlet. (Fig. 4-4)
 - ⒶAir protection guide
- ③ Position the unit so that the air outlet blows perpendicularly to the seasonal wind direction, if possible. (Fig. 4-5)
 - ⒷWind direction

(2) When installing a single outdoor unit (Refer to the next page)

Minimum dimensions are as follows, except for Max., meaning Maximum dimensions, indicated.

Refer to the figures for each case.

- ① Obstacles at rear only (Fig. 4-6)
- ② Obstacles at rear and above only (Fig. 4-7)
- ③ Obstacles at rear and sides only (Fig. 4-8)
- ④ Obstacles at front only (Fig. 4-9)
 - *When using the optional air outlet guides, the clearance is 500 mm or more.
- ⑤ Obstacles at front and rear only (Fig. 4-10)
 - *When using the optional air outlet guides, the clearance is 500 mm or more.
- ⑥ Obstacles at rear, sides, and above only (Fig. 4-11)
 - *Do not install the optional air outlet guides for upward airflow.

(3) When installing multiple outdoor units (Refer to the next page)

Leave 10 mm space or more between the units.

- ① Obstacles at rear only (Fig. 4-12)
- ② Obstacles at rear and above only (Fig. 4-13)
 - *No more than 3 units must be installed side by side. In addition, leave space as shown.
 - *Do not install the optional air outlet guides for upward airflow.
- ③ Obstacles at front only (Fig. 4-14)
 - *When using the optional air outlet guides, the clearance is 1000 mm or more.
- ④ Obstacles at front and rear only (Fig. 4-15)
 - *When using the optional air outlet guides, the clearance is 1000 mm or more.
- ⑤ Single parallel unit arrangement (Fig. 4-16)
 - *When using the optional air outlet guides installed for upward airflow, the clearance is 1000 mm or more.
- ⑥ Multiple parallel unit arrangement (Fig. 4-17)
 - *When using the optional air outlet guides installed for upward airflow, the clearance is 1500 mm or more.
- ⑦ Stacked unit arrangement (Fig. 4-18)
 - *The units can be stacked up to 2 units high.
 - *No more than 2 stacked units must be installed side by side. In addition, leave space as shown.